

AC TRANSDUCER

RIBXGT420-RMS

VFD Compatible True RMS Current Transducer, Split Core, Multi-Range (0-10, 20, and 50A), 4-20 mA Terminal Output

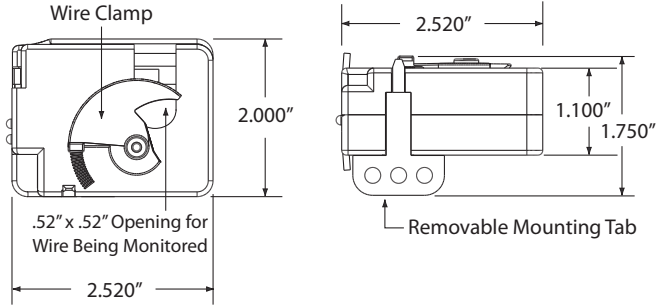

SPECIFICATIONS

- Operating Temperature:** -30 to 140° F
- Humidity Range:** 5 to 95% (noncondensing)
- Sensor Type:** Internal, with 4-20 mA Transmitter Output
- Sensor Range:** 0-10 Amps, 0-20 Amps, or 0-50 Amps (See Selection Guide Below)
- Accuracy:** ± 2% FS (5% - 100% Span)
- Max Sense Voltage:** 600 Vac
- Frequency:** 10-400 Hz
- Approvals:** UL Listed, UL508, C-UL, CE, RoHS
- Mounting/Installation:** Removable mounting tab provided. The wire clamp locks against the wire being monitored, securing the unit in place.

OUTPUT LOAD RESISTANCE	SUPPLY VOLTAGE	
	Minimum	Maximum
800 ohms	24 Vdc	35 Vdc
500 ohms	18 Vdc	35 Vdc
350 ohms	15 Vdc	35 Vdc
250 ohms	13 Vdc	35 Vdc
200 ohms	12 Vdc	35 Vdc
100 ohms	10 Vdc	35 Vdc
50 ohms	9 Vdc	35 Vdc

True RMS: True RMS current transducers can measure the current of waveforms that are not purely sinusoidal. This enables them to be used in applications involving VFDs, phase angle dimmers, switching power supplies and more.

DIP Switch 1	DIP Switch 2	Sensing Range
OFF	OFF	0-10A
OFF	ON	0-20A
ON	OFF	0-50A

